

SECTION C

CRYOGENIC AND THERMAL SUPPORTS

0	21/06/14	GENERAL REVISION	DDG	EAR
REV.	DATE	EDITED FOR :	DRAW.	REV.



CONTENTS

- THERMAL, COLD & CRYOGENIC SUPPORTSC-1
- PREINSULATED SADDLE C-2
- PREINSULATED CLAMP BASE C-3
- PREINSULATED CLAMP FOR HANGER C-4
- PREINSULATED AXIAL STOP C-5
- HIGH STRENGTH AXIAL STOP C-6
- PREINSULATED "SANDWICH" FOR TRUNNION C-7
- CLAMP BASE WITH INSULATED BLOCK C-8

0	21/06/14	GENERAL REVISION	DDG	EAR
REV.	DATE	EDITED FOR :	DRAW.	REV.



PREINSULATED SUPPORTS: THERMAL, COLD & CRYOGENIC SUPPORTS

Preinsulated supports use high density, mechanically capable, insulation materials between the pipe and the steel clamp or shoe in order to bear the load and movement of the pipe while ensuring the following additional benefits compared to conventional supports:

- Minimize thermal losses from the piping system to the outside environment through the pipe support
- Avoid the formation of ice blocks or condensation around the support in cryogenic or cold service
- Guarantee personal protection around hot or cold pipelines
- Make it technically and economically viable to support very high temperature pipelines which use very special steel grades

In order to be able to provide these solutions to our clients, at PIHASA we have established alliances with several partners that provide us with access to the most innovative and efficient materials that can be used for the fabrication and supply of preinsulated supports for hot and cold service:

- High density molded polyurethane foam ("PUF"), which is currently the most commonly used insulation material for pipe supports in cold and cryogenic pipelines, with a service temperature range from -196°C up to +100°C
- Cellular glass, very convenient for dual-operation pipelines due to its wide temperature range, from -260°C to +430°C
- Densified hardwood for cold and cryogenic service, which is commonly used as a high-density insulation material for stops and anchors
- Calcium silicate and other inorganic composite materials with a very wide range of densities and temperature ranges, up to +1000°C

It must be taken into consideration that all these insulation materials display their best mechanical properties when working under compression, so the support designs must ensure that load is transferred to the insulation material in such manner. As a result, there are three main types of preinsulated supports:

- a) Simple or guided supports, where the pipe is surrounded by insulation material, which is clamped by the steel support, which rests on the supporting structure or is hanged from it. When lateral loads are significant, double, triple or quadruple clamp bases are used, so that loads on insulation materials work under compression.
- b) Axial stops, where the pipe is welded with a center thrust ring that becomes embedded into the insulation materials, and the clamps bear end thrust rings that ensure that the axial load becomes a compression load when transferred to the steel support.
- c) "Sandwich" type supports, which are very typical for supporting trunnions, elbows, ladders or equipment, or even as lower insulation materials for clamp bases. These are square, rectangular or circular sized blocks with countersunk drills or insulation washers that ensure that there is no thermal bridge through the bolts that connect both ends of the sandwich .

0	21/06/14	GENERAL REVISION	DDG	EAR
REV.	DATE	EDITED FOR :	DRAW.	REV.



PREINSULATED SADDLE

FIG.: 5000

SECTION C
2

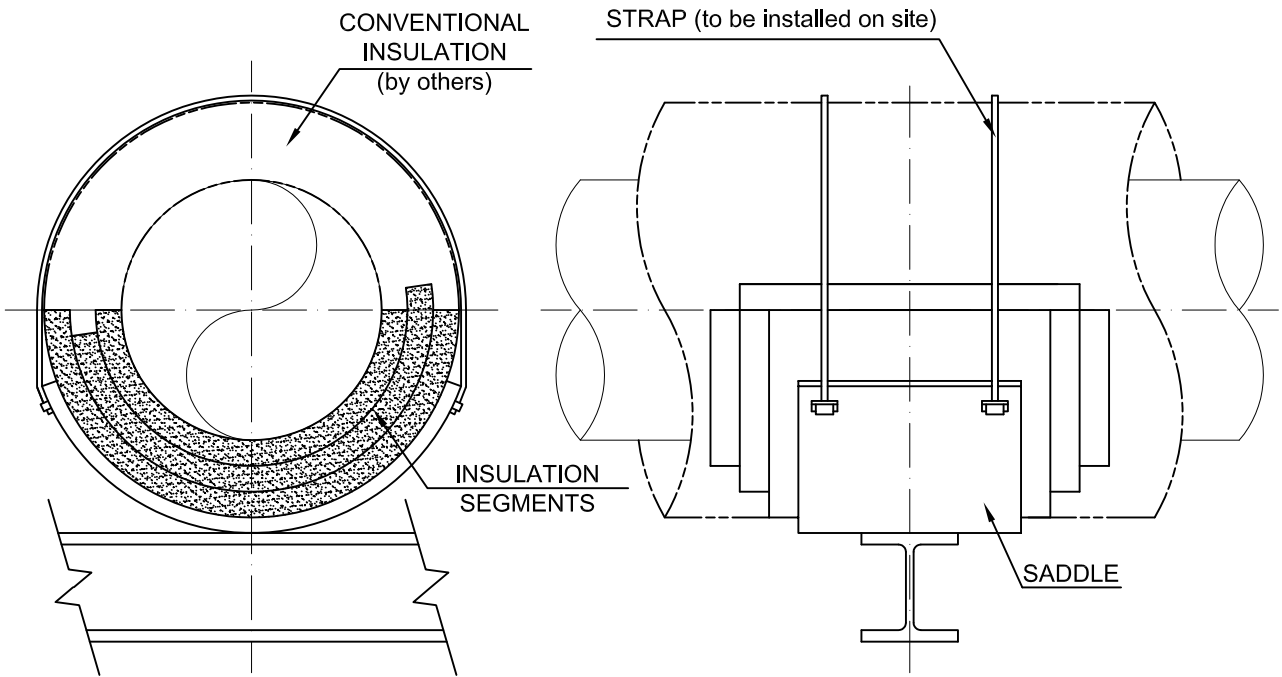

FRONT VIEW

LATERAL VIEW

0	21/06/14	GENERAL REVISION	DDG	EAR
REV.	DATE	EDITED FOR :	DRAW.	REV.

PREINSULATED CLAMP BASE

FIG.: 5100

SECTION C
3

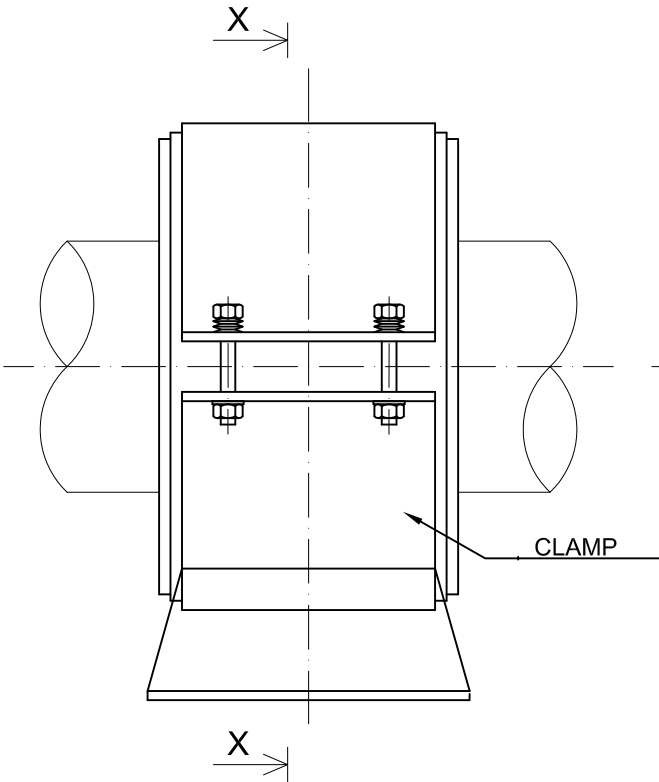

LATERAL VIEW

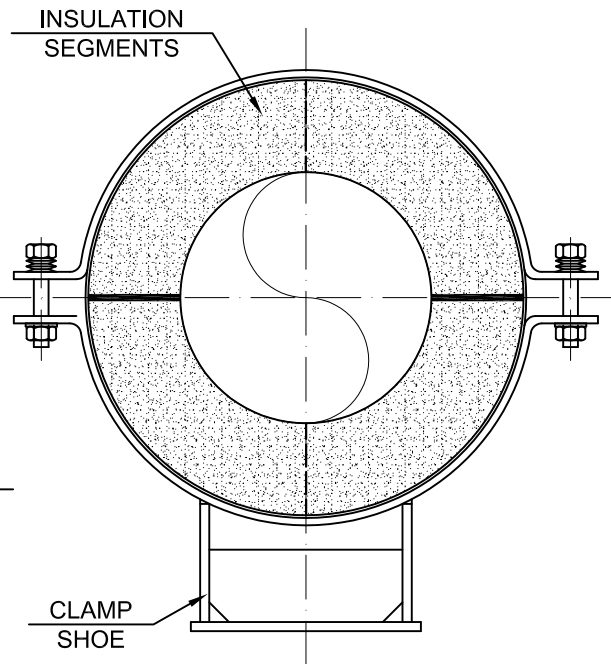

VIEW X-X

0	21/06/14	GENERAL REVISION	DDG	EAR
REV.	DATE	EDITED FOR :	DRAW.	REV.

PREINSULATED CLAMP FOR HANGER

FIG.: 5200

SECTION C
4

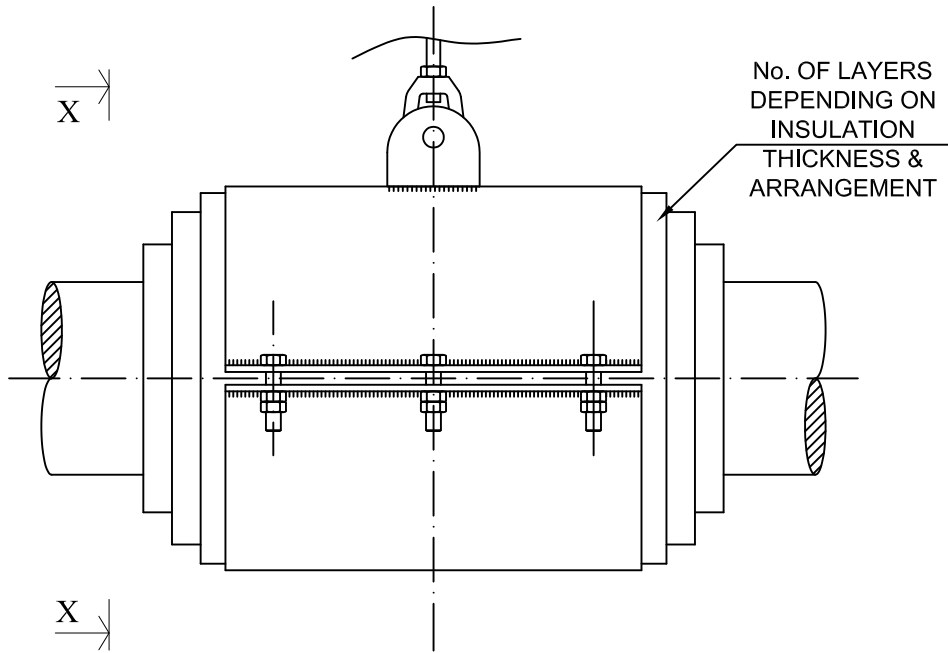

LATERAL VIEW

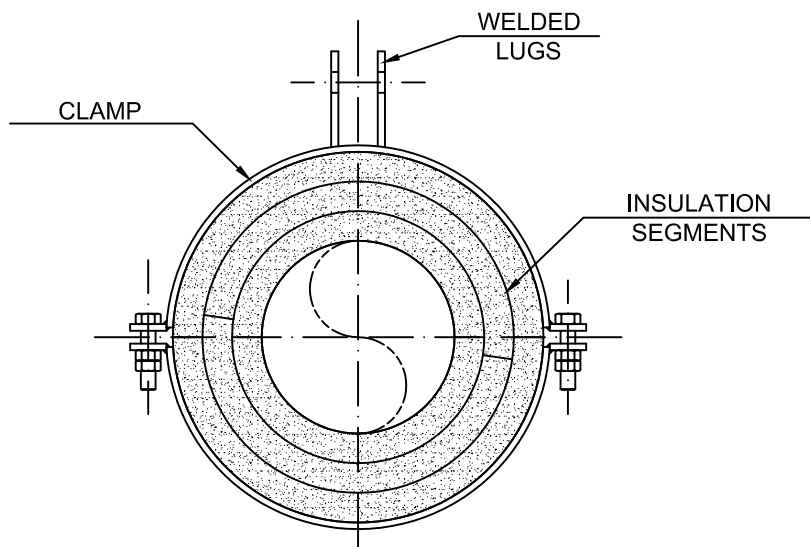

VIEW X-X

0	21/06/14	GENERAL REVISION	DDG	EAR
REV.	DATE	EDITED FOR :	DRAW.	REV.

PREINSULATED AXIAL STOP

FIG.: 5300

SECTION C
5

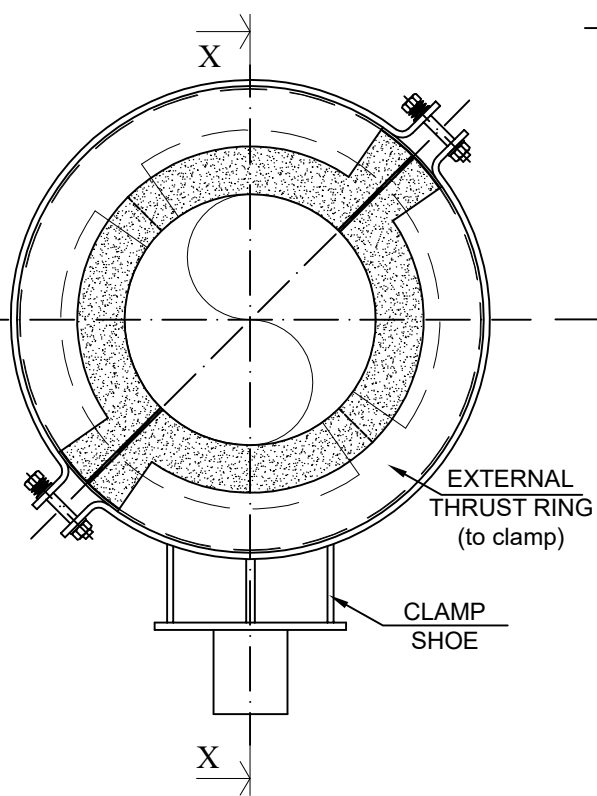

FRONT VIEW

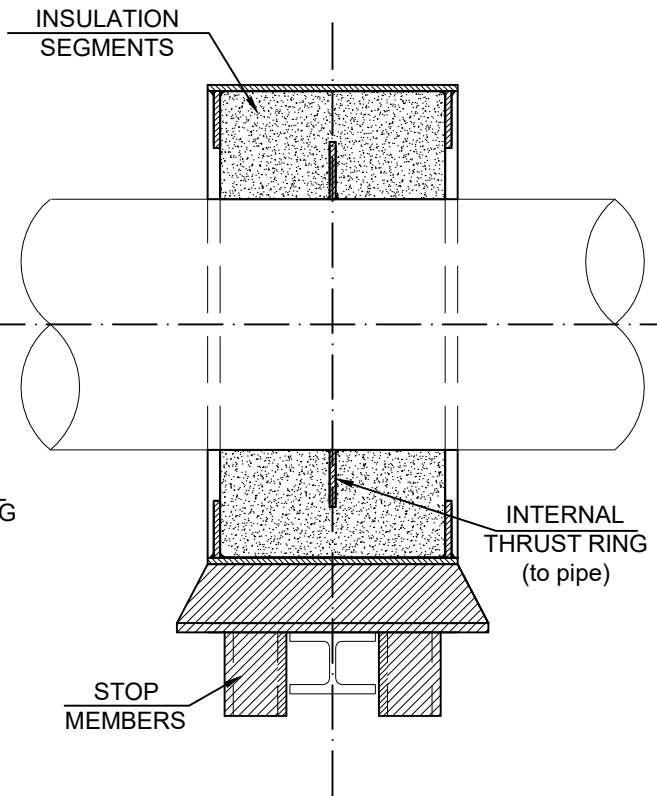

VIEW X-X

0	21/06/14	GENERAL REVISION	DDG	EAR
REV.	DATE	EDITED FOR :	DRAW.	REV.



HIGH STRENGTH AXIAL STOP

FIG.: 5400

SECTION C
6

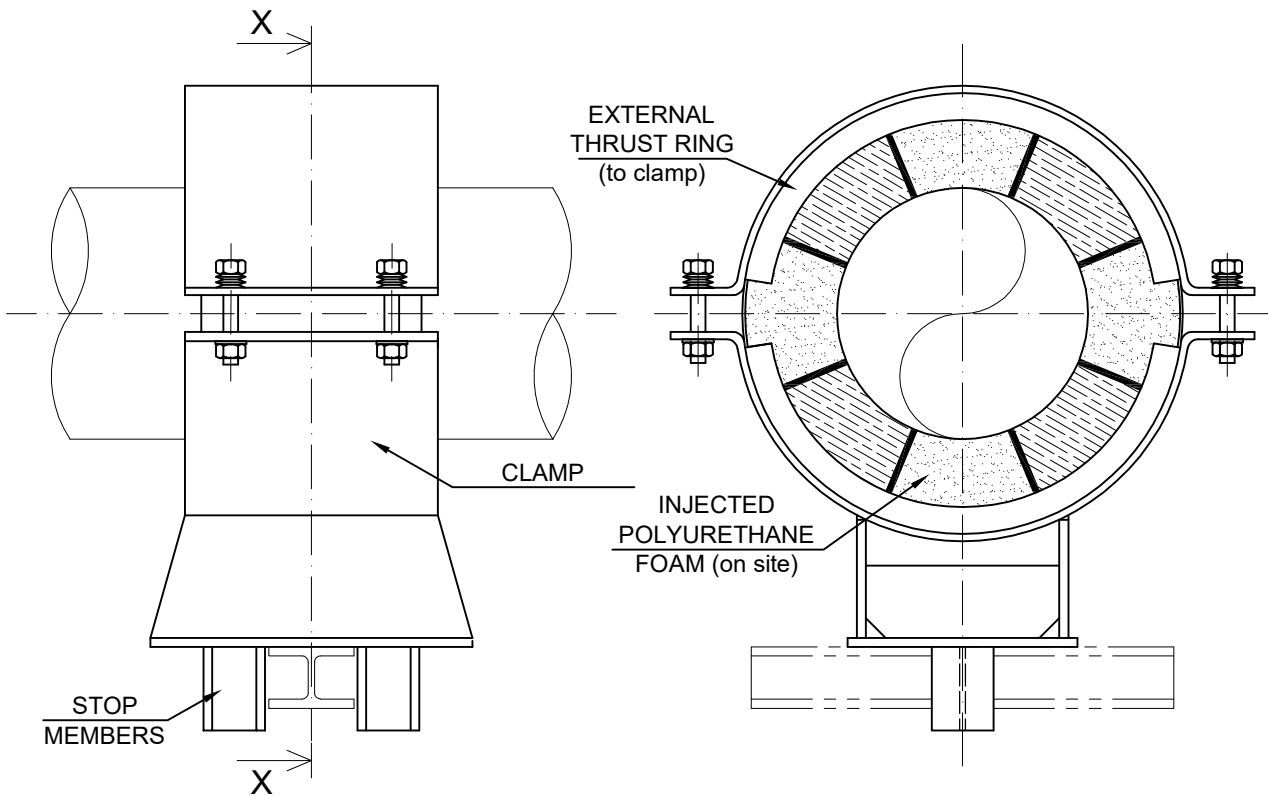

LATERAL VIEW

FRONT VIEW

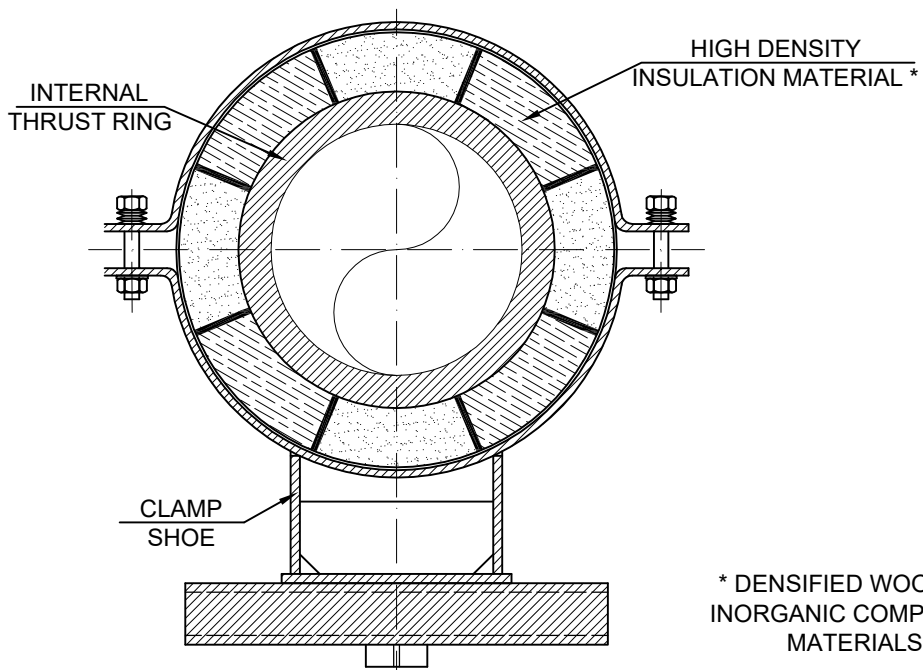

VIEW X-X

* DENSIFIED WOOD OR
INORGANIC COMPOSITE
MATERIALS

0	21/06/14	GENERAL REVISION	DDG	EAR
REV.	DATE	EDITED FOR :	DRAW.	REV.



PREINSULATED "SANDWICH" FOR TRUNNION

FIG.: 5500

SECTION C
7

FRONT VIEW

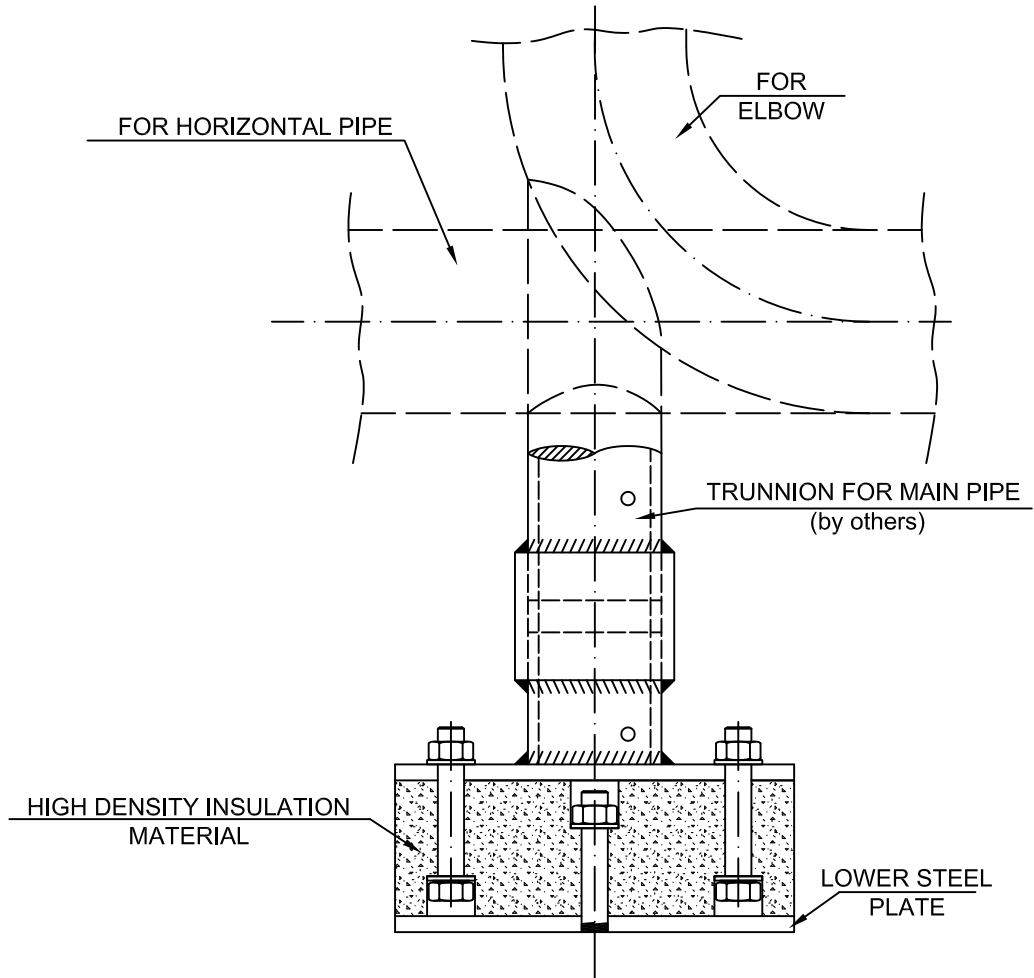

PLANT VIEW

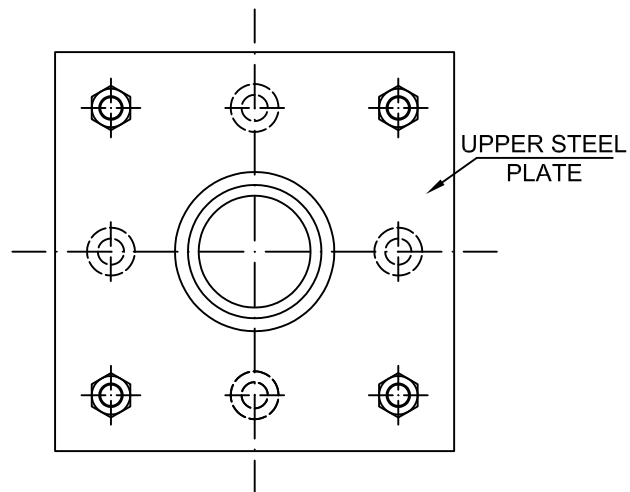

0	21/06/14	GENERAL REVISION	DDG	EAR
REV.	DATE	EDITED FOR :	DRAW.	REV.

CLAMP BASE WITH INSULATION BLOCK

FIG.: 5600

SECTION C

8

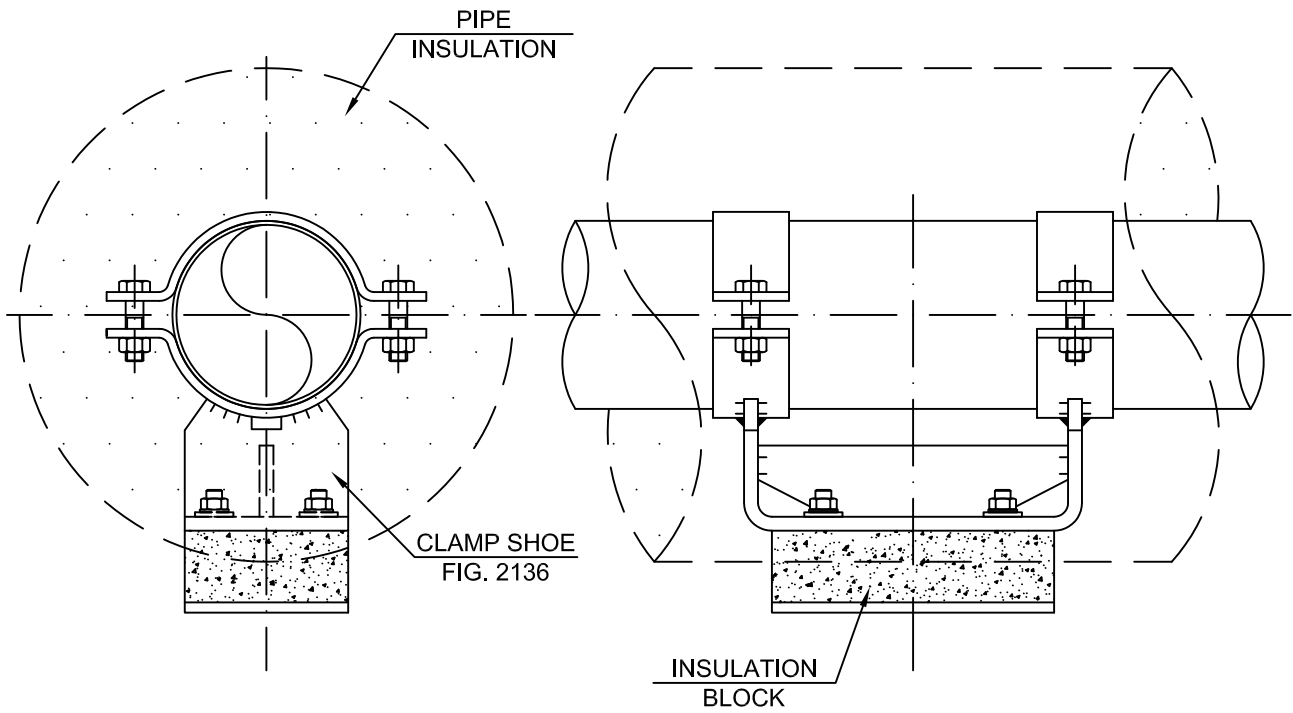

INSULATION BLOCK DETAILS

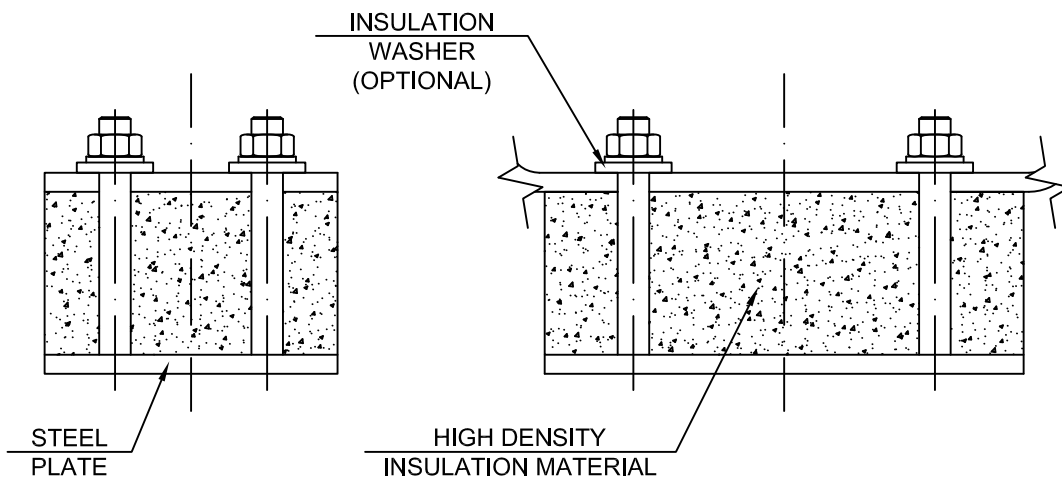

0	30/07/19	GENERAL REVISION	DDG	EAR
REV.	DATE	EDITED FOR :	DRAW.	REV.